

# LF10 Pressure Switch

The LF10 pressure switches are used to regulate the tank pressure between two preset values on electrically driven air compressors. They are available with an unloader valve, which prevents compressors from starting under load, and an auto-off disconnect lever for manual cut off the compressor. A four port manifold style is available which provides a means for easy mounting of valves and gauges.



## Specification

Model	LF10-1H/LF10-4H				LF10A-1H/LF10A-4H			
Media	Air	Air	Air	Air	Air	Air	Air	Air
Operating Pressure Range	25-100 PSI	35-150 PSI	50-175 PSI	70-200 PSI	25-100 PSI	35-150 PSI	50-175 PSI	70-200 PSI
Factory Setting	55-80 PSI	85-115 PSI	110-150 PSI	30-175 PSI	55-80 PSI	85-115 PSI	110-150 PSI	30-175 PSI
Differential	20-35 PSI	30-40 PSI	35-55 PSI	40-55 PSI	20-35 PSI	30-40 PSI	35-55 PSI	40-55 PSI
Electrical Rating	240VAC,12A 120VAC,20A				26A/120VAC 26A/240VAC			
Contact Arrangement	Normal Close (NC)				Normal Close (NC)			
Connection	1/4,3/8Male or Female NPT(1Port)				1/4,3/8Male or Female NPT(1Port)			
	1/4,Female NPT(4Ports)				1/4,Female NPT(4Ports)			

Conversion: 1Kgf/cm<sup>2</sup>=14.2PSI 1Bar=14.5PSI Other connections are available on request.

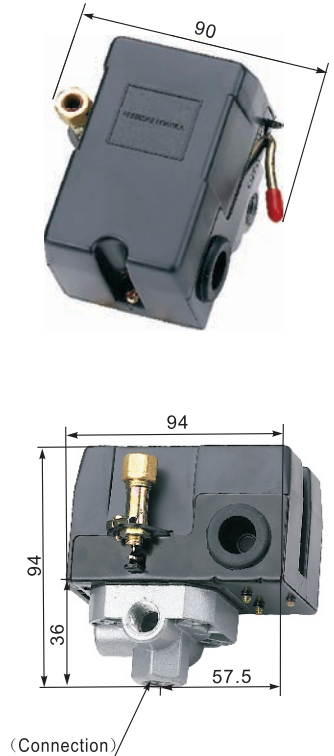

## LF10 Order Ref No:

i.e.: LF10(A)-1H11111-85PSI-115PSI

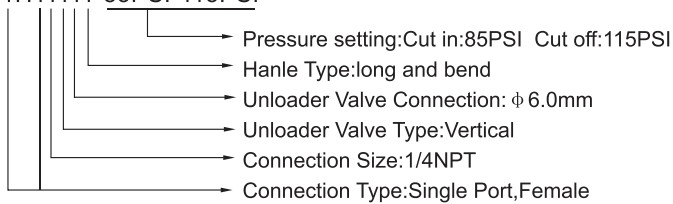

Number	Connection Type		Connection Size	Unloader Valve Type	Unloader Valve Connection	Handle Type
0	/	/	/	Without	Without	Without
1	Single Port	Female	1/4NPT	Vertical	φ 6.0mm	Long and bend
2	/	Male	3/8NPT	Horizontal	φ 6.4mm	Long and straight
3	/	/	R1/4	/	φ 6.5mm	Short and bend
4	Four Ports	/	R3/8	/	/	Short and straight
5	/	/	G1/4	/	/	/
6	/	/	G3/8	/	/	/

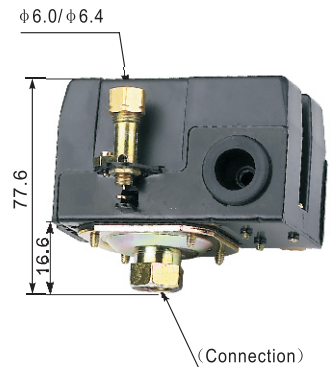

尺寸单位: mm  
(Dimension in mm)